

THIS DRAWING IS UNPUBLISHED. RELEASED FOR PUBLICATION
 © COPYRIGHT BY TYCO ELECTRONICS CORPORATION. ALL RIGHTS RESERVED.

LOC	DIST	REVISIONS			
P	LTR	DESCRIPTION	DATE	DWN	APVD
AJ	16	N	REVISED PER ECO 07-010538	04MAY2007	DW GM

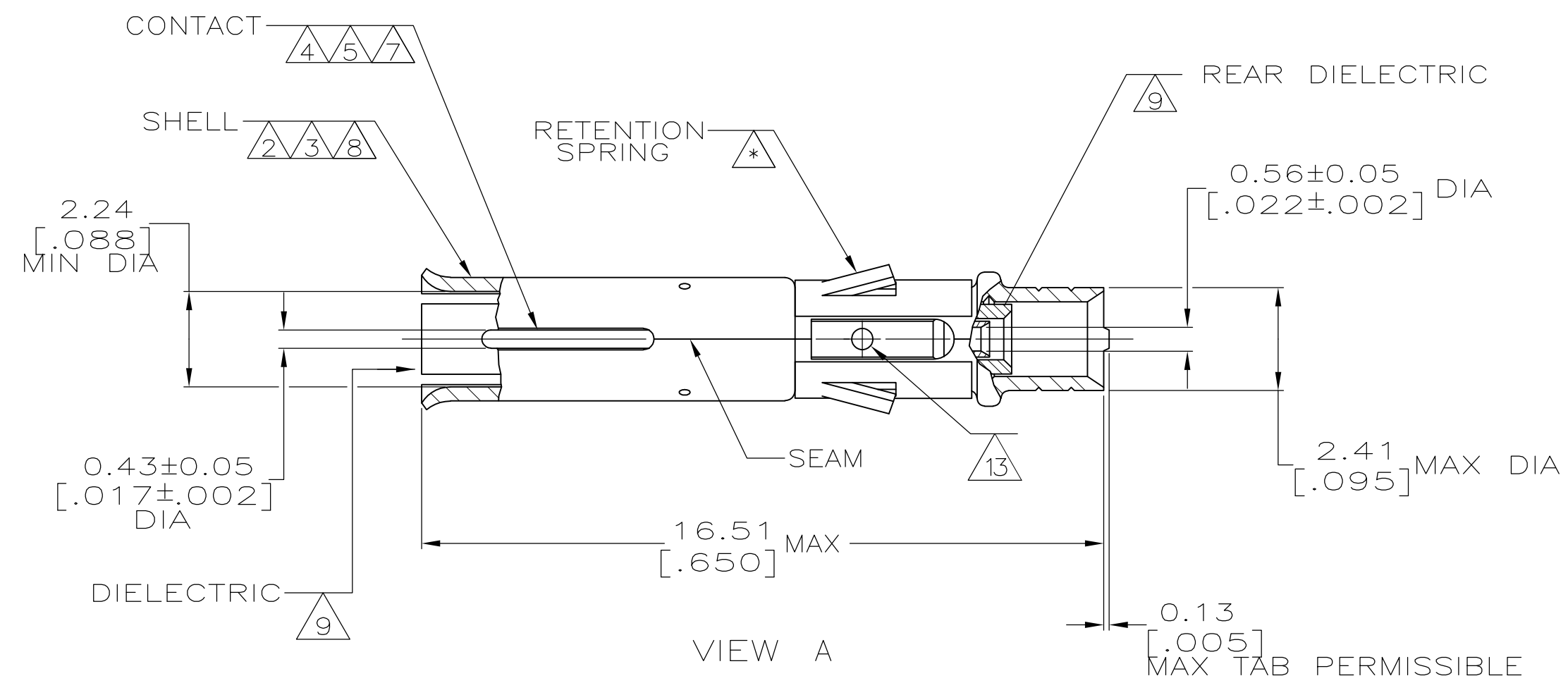

VIEW A

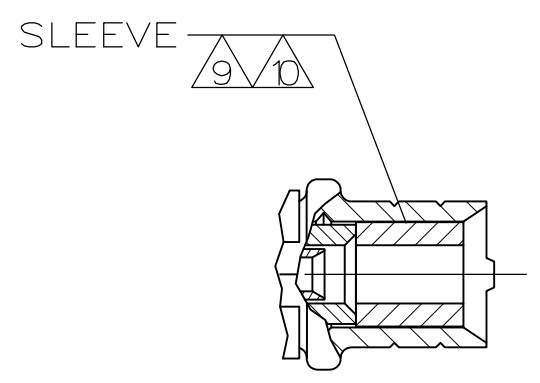

VIEW B

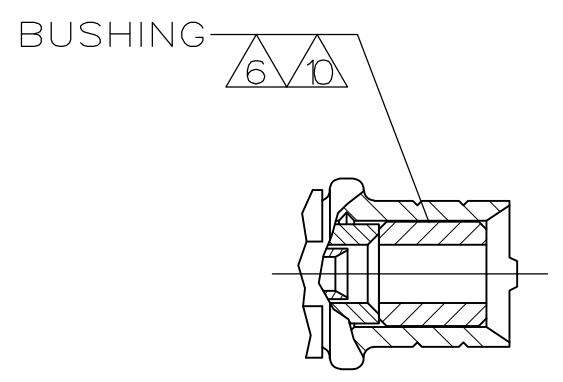

VIEW C

1. FOR CABLE SELECTION, FERRULE AND HANDTOOL PART NUMBERS, SEE I.S. 2024-2

- △2 GOLD PLATE PER MIL-G-45204,.000027 MINIMUM THICKNESS
- △3 GOLD PLATE PER MIL-G-45204,.000045 MINIMUM THICKNESS
- △4 GOLD PLATE PER MIL-G-45204,.000030 MINIMUM THICKNESS
- △5 GOLD PLATE PER MIL-G-45204,.000050 MINIMUM THICKNESS
- △6 TIN PLATE PER MIL-T-10272
- △7 BRASS PER QQ-B-626
- △8 BRASS PER MIL-C-50
- △9 POLYPROPYLENE,GENERAL PURPOSE
- △10 BRASS PER ASTM-B-135
- △11 STAINLESS STEEL,SPRING TEMPER PER QQ-S-766
- △12 PTFE PER MIL-P-19468
- △13 SIGHT HOLE VISIBLE THROUGH THE PORT SLOT ON RETENTION SPRING

OBSOLETE	A	△2 △4	△7 △8 △9 △11	1-51565-5
	A	△2 △4	△7 △8 △9 △11	1-51565-4
	B	△3 △5	△7 △8 △9 △10 △11 △12	1-51565-3
OBSOLETE	C	△3 △5 △6	△7 △8 △9 △10 △11	51565-6
OBSOLETE	B	△3 △5	△7 △8 △9 △11	51565-5
OBSOLETE	A	△3 △5	△7 △8 △9 △11	51565-4
	C	△2 △4 △6	△7 △8 △9 △10 △11	51565-3
	B	△2 △4	△7 △8 △9 △11	51565-2
	A	△2 △4	△7 △8 △9 △11	51565-1
	VIEW	FINISH	MATERIAL	PART NUMBER

THIS DRAWING IS A CONTROLLED DOCUMENT.

DWN B. WERNER 4-23-91
 CHK D. DOYE 5-3-91
 APVD -

tyco Electronics Tyco Electronics Corporation
 Harrisburg, PA 17105-3608

NAME: SOCKET ASSEMBLY, SERIES SUBMINIATURE

SIZE: A2 CAGE CODE: 00779 DRAWING NO: C=51565 RESTRICTED TO: -

SCALE: 8:1 SHEET: 1 of 1 REV: N

DIMENSIONS: INCHES TOLERANCES UNLESS OTHERWISE SPECIFIED:
 0 PLC ± -
 1 PLC ± -
 2 PLC ± -
 3 PLC ± -
 4 PLC ± -
 ANGLES ± -

MATERIAL: SEE TABLE FINISH: SEE TABLE WEIGHT: -

CUSTOMER DRAWING